

ASSEMBLY VIEW



NSi Industries, LLC

TITEL- *Assembly View Of Cast connector TCP. 350*

SCALE- *N.T.S.* FINISH- _____

	NAME	DATE
DRAWN	SD	09/05/2006
CHECKED	KM	09/05/2006
APPROVED	KM	09/05/2006
MATERIAL	-	
TOLERANCE	-	
Drawing No.	-	2768/a

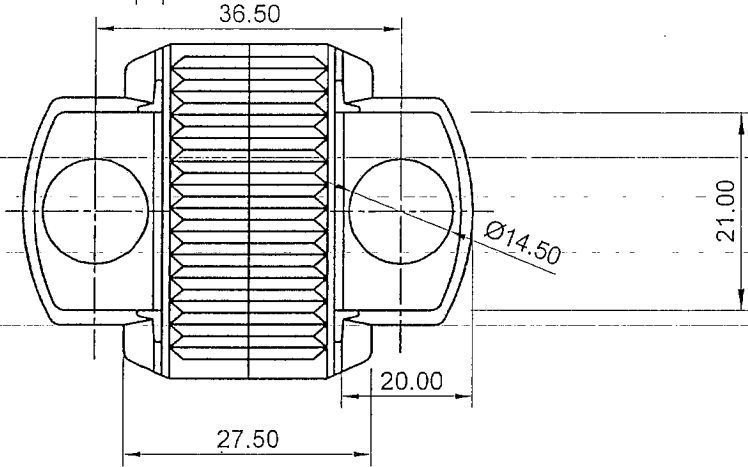
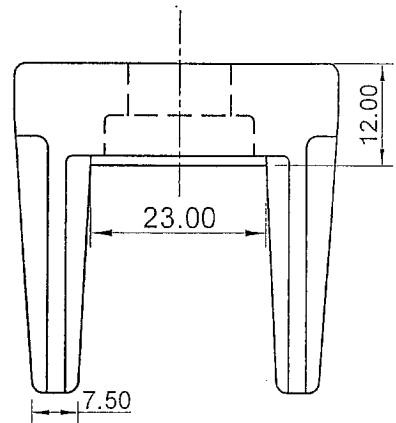
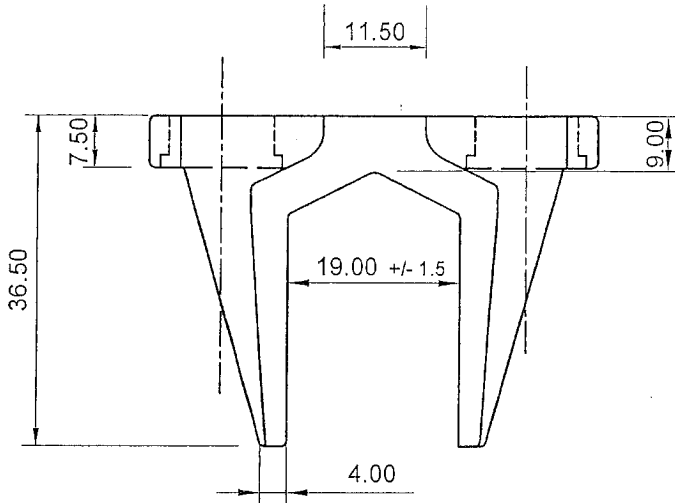
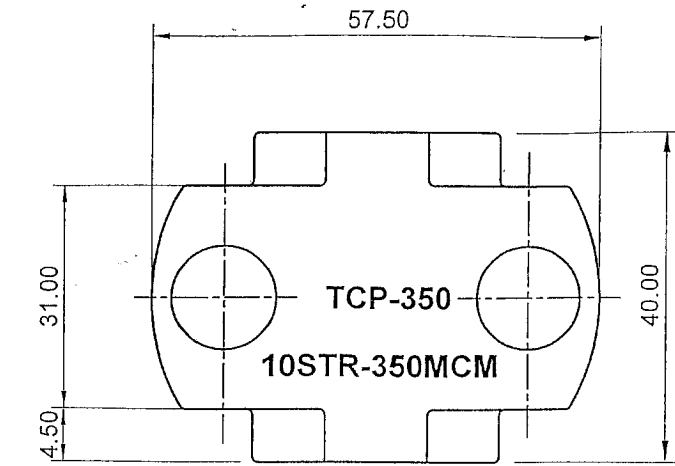

NSi Industries, LLC

TITEL - Body TCP 350

SCALE - N.T.S. FINISH - Tin Plated

All dimensions are in mm

	NAME	DATE
DRAWN	SD	09/05/2006
CHECKED	KM	09/05/2006
APPROVED	KM	09/05/2006
MATERIAL	-	C-956
TOLERANCE	-	±0.50
Drawing No.	-	2768/b

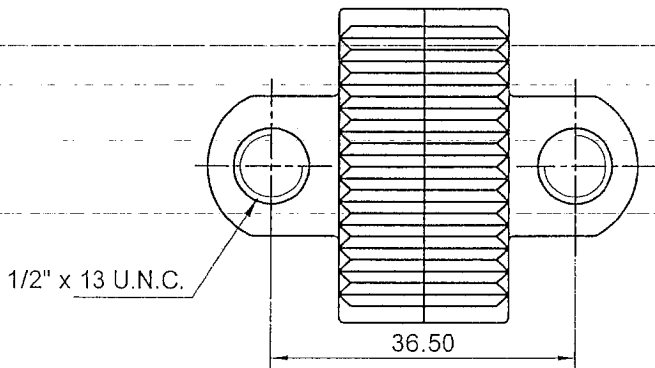
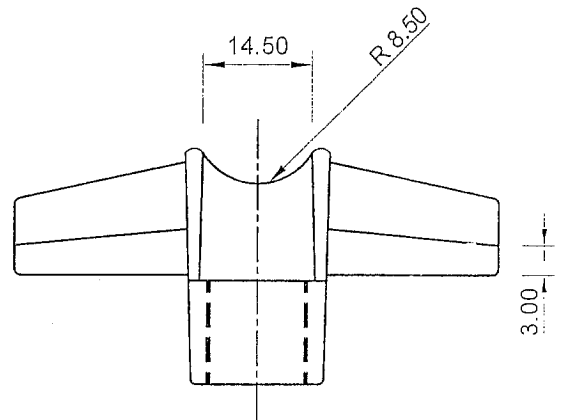
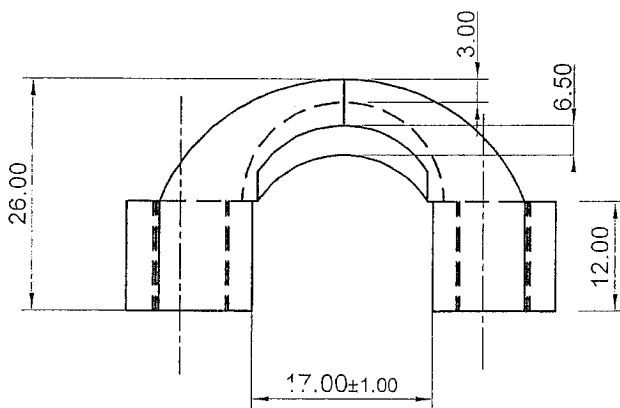
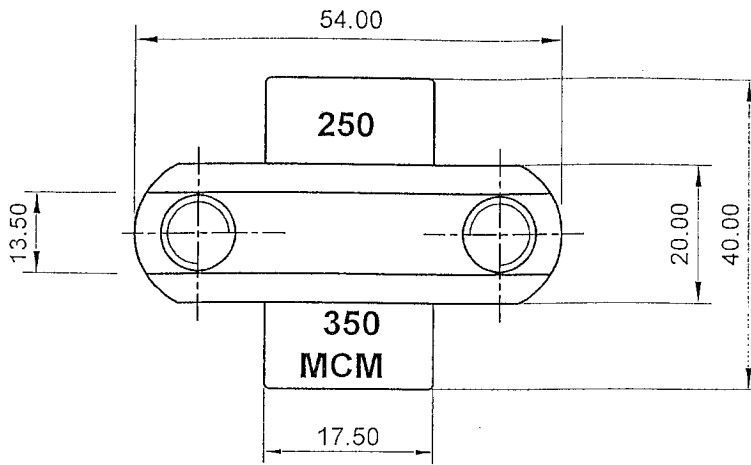

NSi Industries, LLC

TITEL - Base TCP 350

SCALE- N.T.S. FINISH- Tin Plated

All dimensions are in mm

	NAME	DATE
DRAWN	SD	09/05/2006
CHECKED	KM	09/05/2006
APPROVED	KM	09/05/2006
MATERIAL	- C-956	
TOLERANCE	- ±0.50	
Drawing No.	- 2768/c	

BOLT "A"

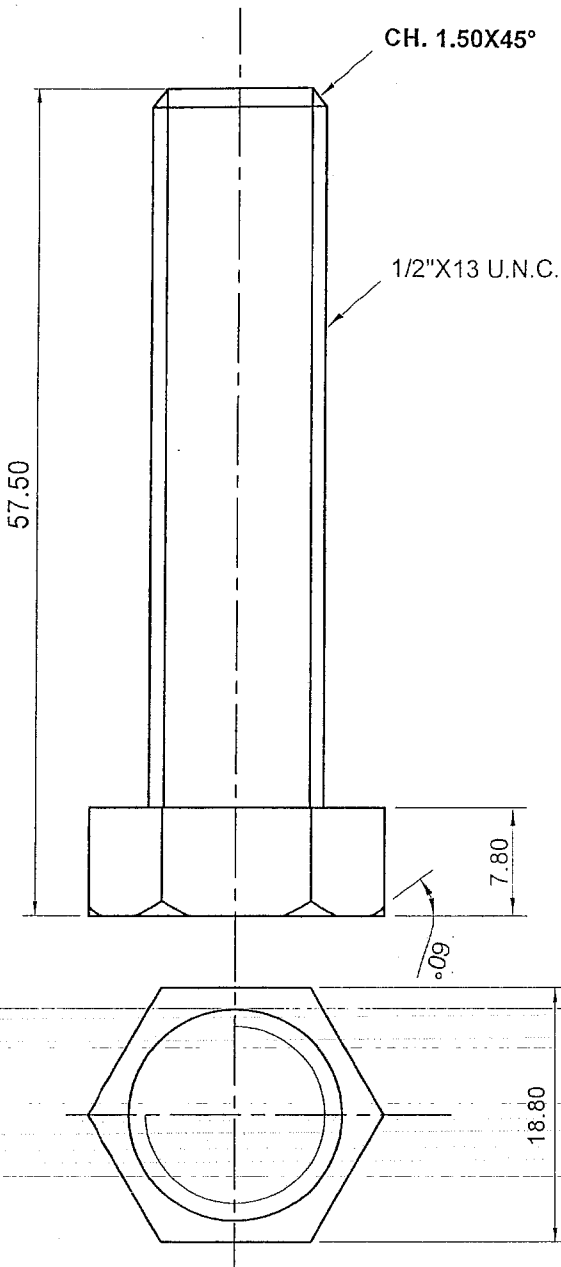

"B"

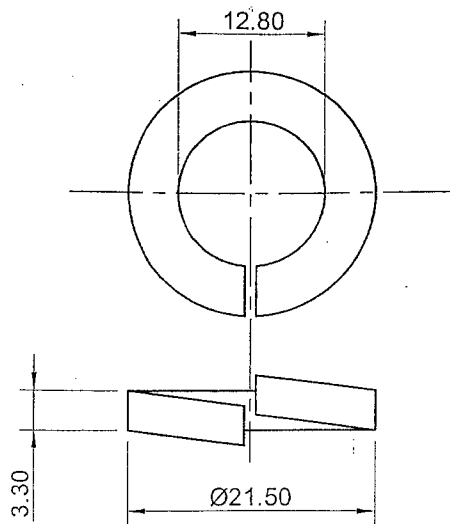

RUBBER WASHER "C"

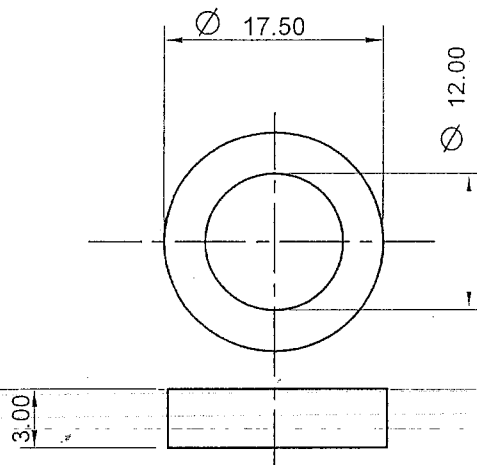

ITEM	MATERIAL
A	S.S304
B	S.S304
C	NEOPRENE



NSi Industries, LLC

TITEL - *Accesorios TCP 350*

SCALE - *N.T.S.* FINISH - *Natural*

All dimensions are in mm

	NAME	DATE
DRAWN	SD	09/05/2006
CHECKED	KM	09/05/2006
APPROVED	KM	09/05/2006
MATERIAL	-	<i>As Per Chart</i>
TOLERANCE	-	± 0.25
Drawing No.	-	2768/d

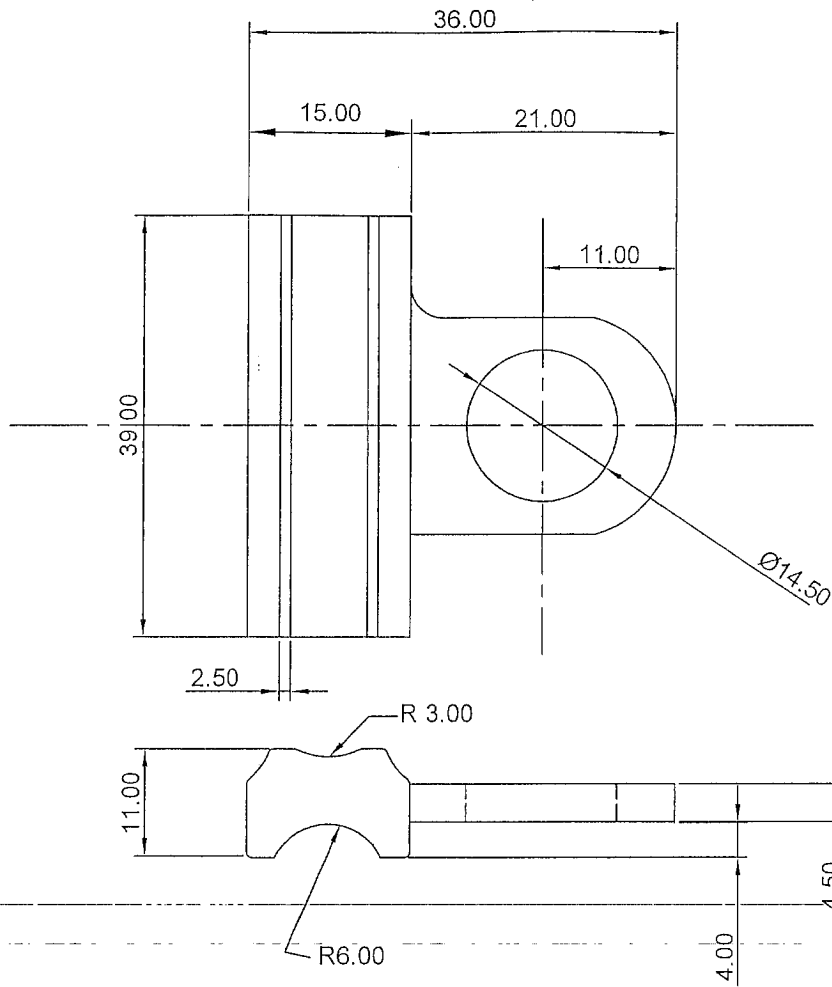

NSi Industries, LLC

TITEL - *Spacer TCP 350*

SCALE- *N.T.S.* FINISH - *Tin Plated*

All dimensions are in mm

	NAME	DATE
DRAWN	SD	09/05/2006
CHECKED	KM	09/05/2006
APPROVED	KM	09/05/2006
MATERIAL	- C-83300	
TOLERANCE	- ± 0.25	
Drawing No.	- 2768/e	