

REV	DATE	REVISED	BY	ECN	C'K'D
A		RELEASED			
B	8/28/23	UPDATED ITEM SPECIFCATION	DC	23-00015	SSM
C	6/5/24	UPDATED VAALOX TO VALOX	XGP	24-00074	SSM

FUSE TABLE	
Overcurrent Protection, Fuse Required Class	Maximum Amp Rating
Class J	110A
Class T	110A
Class RK1	60A
Class RK5	30A
Class G	60A
Class CC	30A

FEATURES:

- 1. AVAILABLE IN FINGER SAFE STYLE MODEL ONLY THAT INCLUDE END PLATES AND HINGED COVER
- 2. FINGER SAFE TO IP20. PER. IEC60529
- 3. cULus LISTED TO UL 1953 AND 1059
- 4. AL9CU RATED FOR USE WITH COPPER OR ALUMINUM CONDUCTOR CLASS B & C, AND OPERATING TEMP OF 90C
- 5. VOLTAGE RATING 600 V
- 6. DEFAULT SCCR (SHORT CIRCUIT CURRENT RATING) WITH CORRECT FUSING = 100kA
- 7. QUICK RELEASE LOCKING MECHANISM TO DISCONNECT FROM STD.35MM DIN RAIL
- 8. OVAL ALIGN MOUNTING HOLE AT BASE ON EITHER WIRE ENTRY END
- 9. MATERIAL: COVER AND END PLATES = LEXAN 500R POLYCARBONATE
- 10. MATERIAL: BASE AND SIDE PANELS = VALOX NYLON 6/6 GF30%
- 11. MATERIAL: CONNECTOR BLOCK 6061T6 ALUMINUM TIN PLATED
- 12. MATERIAL: WIRE PORT SCREWS, STEEL TIN PLATED
- 13. MATERIAL: CONNECTOR TO BLOCK SECURITY SCREW, STEEL TIN PLATED
- 14. MULTI-PORT GANGING OF SAME SIZE BLOCK (SML, MED, LRG)
- 15. MAXIMUM AMPACITY PER POLE = 760A
- 16. PRIMARY (LINE, RUN, MAIN) SIDE = 500 MCM
- 17. PRIMARY MAXIMUM TORQUE VALUE = 442 IN.LBF
- 18. PRIMARY STRIP LENGTH = 1.000"
- 19. MAXIMUM AMPACITY PER POLE = 760A
- 20. SECONDARY (LINE, RUN, MAIN) SIDE = 4 AWG
- 21. SECONDARY MAXIMUM TORQUE VALUE = 35 IN.LBF
- 22. SECONDARY STRIP LENGTH = .50"

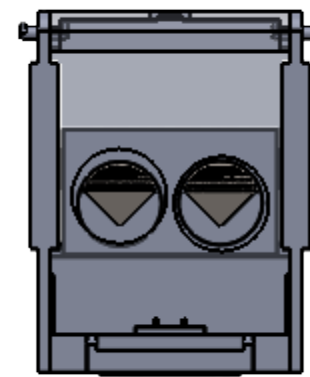
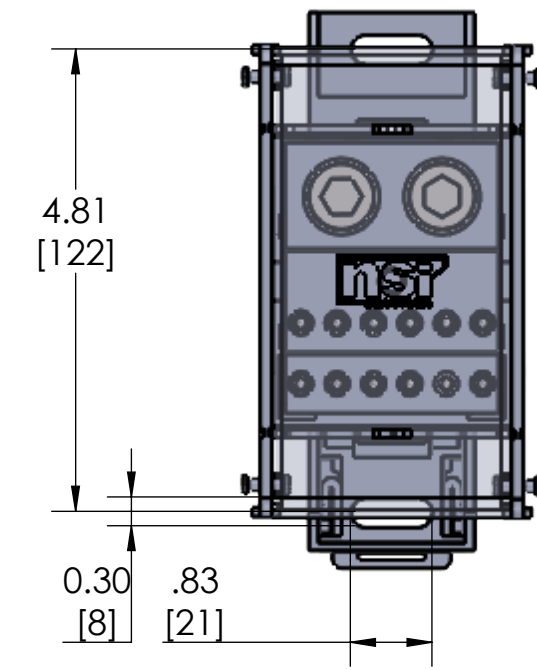
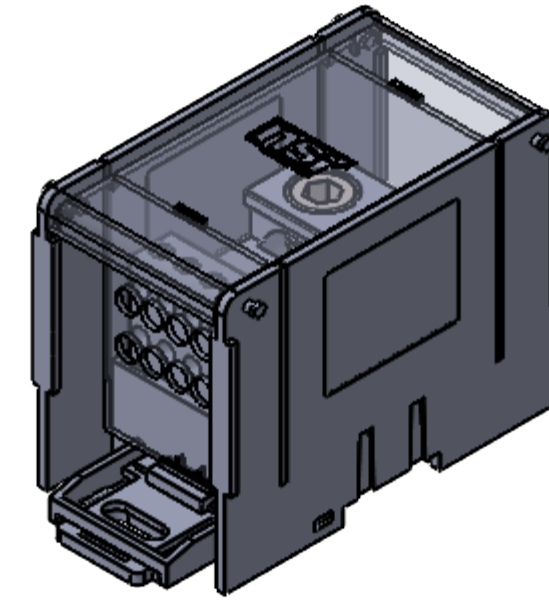

RUN SIDE

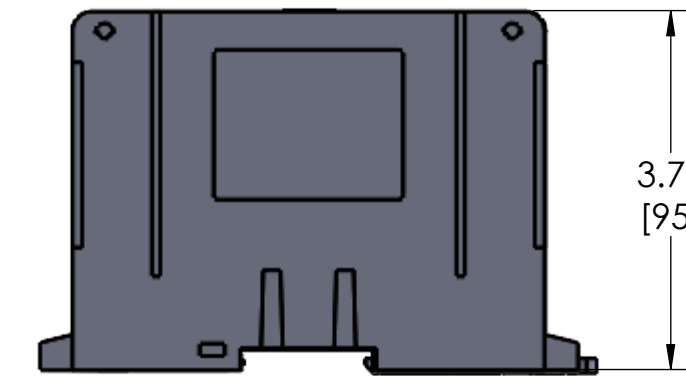

DIN RAIL STYLE

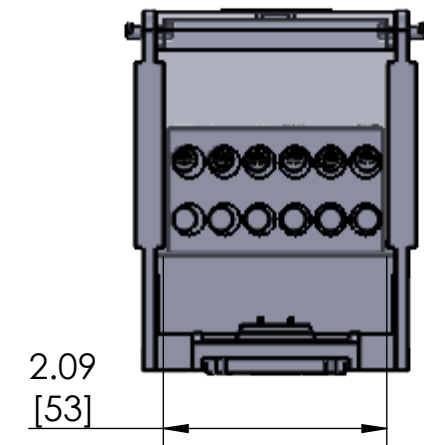

TAP SIDE

2: TORQUE VALUES

WIRE RANGE (MCM/AWG)	CONNECTOR SIZE									
	750	600	500	350	250	3/0	2/0	1/0	#2	#4
750 - 600	550	550								
500	550	450	450							
400	550	450	450							
350	550	400	400	400						
250	550	360	360	360	360					
4/0 - 3/0	550	250	250	250	250	250				
2/0	550	180	180	180	180	180	120			
1/0	550	180	180	180	180	180	80	80		
#1		150	150	150	150	150	65	65		
#2 - #3		150	150	150	150	150	65	65	65	
#4 - #6		150	110	110	110	110	55	55	35	35
#8				75			45	45	25	25
#10 - #14				35			25	25	15	15

NPDB -	212 -	500 -	1
NSI PRODUCT GROUP POWER DISTRIBUTION BLOCKS	1ST DIGIT = # OF PRIMARY COND. 2ND DIGIT = # OF SECONDARY COND.	MAXIMUM WIRE SIZE	NUMBER OF POLES

- NOTES:
- DIMENSIONS IN BRACKETS [] ARE IN MM ROUNDED OFF TO THE NEAREST MM, UNLESS OTHERWISE SPECIFIED AND ARE FOR REFERENCE ONLY
 - MATERIALS: BASE, POLE SEPARATING SIDE AND LOCK - NYLON 66 GF30%
BLOCK AND RETENTION SCREWS - TIN PLATED ALUMINUM
FINGER SAFE COVERS - POLYCARBONATE
BLOCK MOUNTING HARDWARE - STAINLESS STEEL
 - MAY BE USED IN ANY NUMBER OF POLES REQUIRED.

PROPRIETARY AND CONFIDENTIAL		NAME	DATE
THE INFORMATION CONTAINED IN THIS DRAWING IS THE SOLE PROPERTY OF NSI Industries. ANY REPRODUCTION IN PART OR AS A WHOLE WITHOUT THE WRITTEN PERMISSION OF NSI Industries IS PROHIBITED.		DRAWN	XGP 6/5/24
DIN, UNLESS OTHERWISE NOTED, ARE IN INCHES. DECIMAL FRACTIONS SHALL BE TO 0.005 UNLESS OTHERWISE NOTED. ANGLES DO NOT SCALE DRAWINGS 1" = 1"		CHECKED	SSM 6/5/24
MATERIAL		ENG APPR.	
FINISH		MFG APPR.	
SEE NOTES		Q.A.	
SEE NOTES		COMMENTS: TO ORDER NSI PRODUCTS CALL UNITED STATES (704) 439-2420 FOR PRODUCT INFO: www.nsiindustries.com	
DIMENSIONS ARE IN INCHES		TITLE: POWER DISTRIBUTION BLOCKS	
SIZE	DWG. NO.	MODEL NO.	REV
C		NPDB-212-500-1	C
SCALE:1:2 SOLIDWORKS 2022 SHEET 1 OF 1			